

# ADC AD-320

## 20-lb x 2 Capacity Coin Stack Dryer

### Standard Features:

- 20-lb. x 2 capacity
- 8.4 cu. ft. volume per pocket
- 60,000 Btu/hr heat input and 400 cfm per pocket
- 100% Axial airflow
- Steel door with gasketless glass
- 6" Diameter vent connection per pocket
- 1/2" gas connection per pocket
- Independent electrical connections for each tumbler
- Only 38-7/8" deep (for gas and electric)
- Single coin drop
- Front serviceable
- Fits through standard 36" door
- Available in gas, steam and electric heat

### Optional Features:

- Stainless Steel Front, Cabinet & Basket
- S.A.F.E. (Sensor Activated Fire Extinguishing System)



AD-320 Coin Stack Dryer

## Why Purchase ADC AD-320?

### Engineer Driven Design That is Built to Last

Our dryers showcase ADC's engineer-driven approach to design. Bearings are permanently lubricated on the motor and drive system. There are no chains or gear reducers used at ADC; rather, we use V-belts and pulleys for smooth, quiet, and trouble free operation. Our dryer cabinets are electrostatically powder-painted inside and out then baked at 420-degrees fahrenheit before final assembly - ensuring the hardest surface and the longest lasting finish in the industry.

### Component Accessibility

The AD-320 is a dual pocket dryer that offers 98% component accessibility from the front of the tumbler. This feature allows the dryer to be placed against the wall without concern for regular rear maintenance. The AD-320 has a large lightweight lint drawer that is accessible and easy to clean -- only requiring cleaning once a day. It's fine, stainless steel lint screen is standard.

### Rugged Steel Door with Gasketless Door Glass

Our dryer doors are one solid piece of steel with gasketless glass. This eliminates the issue of glass falling out due to wear and tear on rubber gaskets that some manufacturers use to secure their glass. The security and durability that gasketless glass provides is essential to a successful laundromat operation.

### Easy-to-Read, Multilingual Controls

We were the first to bring computer operated dryers to the market and today we continue to be a leader in applying technology to dryer operation. Our years of experience along with our accessible design, easy-to-read LCD screens and our user friendly multilingual interface positions ADC as the pioneer in the laundry industry.

Your local ADC independent authorized distributor



[www.adclaundry.com](http://www.adclaundry.com)

# ADC AD-320

AD-320 Specifications							
Tumbler Capacity (dry weight)	20 lbs. (9.07 kg) x 2						
Tumbler Diameter	27-1/4" (69.22 cm)						
Tumbler Depth	25" (63.5 cm)						
Tumbler Volume	8.4 cu ft (237.86 L)						
Tumbler/Drive Motor	1/3 hp (0.25 kW)						
Blower/Fan Motor	N/A						
Door Opening (diameter)	21-1/2" (54.6 cm)						
Door Sill Height (top pocket/bottom pocket)	50-15/16" (129.4 cm) 12-3/16" (31 cm)						
S.A.F.E. Water Connection	3/4" (11.5 NH) F.N.P.T. 3/4" B.S.P.T. (outside North America)						
Dryers per 20'/40' Container	14 / 28						
Dryers per 48'/53' Truck	34 / 36						
Width	29-3/4" (75.57 cm)						
Depth (gas and electric/steam)	38-7/8" (98.7 cm) / 43-15/16" (111.6 cm)						
Height	78-1/4" (198.8 cm)						
Airflow gas/electric/steam	60 Hz 400 cfm (11.33 cmm) 50 Hz 333 cfm (9.44 cmm)						
Exhaust Connection	6" (15.24 cm)						
GAS MODEL:	<p>Voltage Available 100-240v 1ø 2w 50/60 Hz</p> <p>Approx. Net Wt. 760 lbs (344.7 kg)</p> <p>Approx. Ship Wt. 795 lbs (360.6 kg)</p> <p>Heat Input (per pocket) 60,000 btu/hr (15,120 kcal/hr)</p> <p>Inlet Pipe Connection 1/2" F.N.P.T. 1/2" B.S.P.T. (CE and Australia Only)</p>						
ELECTRIC MODEL:	<p>Voltage Available 208-416v 1,3ø 2,3,4w 50/60 Hz</p> <p>Approx. Net Wt. 760 lbs (344.7 kg)</p> <p>Approx. Ship Wt. 795 lbs (360.6 kg)</p> <table border="1"> <tr> <td>Oven Size per pocket</td> <td></td> </tr> <tr> <td>kW</td> <td>Btu/hr (kcal/hr)</td> </tr> <tr> <td>15</td> <td>51,228 (12,910)</td> </tr> </table>	Oven Size per pocket		kW	Btu/hr (kcal/hr)	15	51,228 (12,910)
Oven Size per pocket							
kW	Btu/hr (kcal/hr)						
15	51,228 (12,910)						
STEAM MODEL: *	<p>Voltage Available 100-240v 1ø 2w 50/60 Hz</p> <p>Approx. Net Wt. 873 lbs (396.0 kg)</p> <p>Approx. Ship Wt. 949 lbs (430.5 kg)</p> <p>Steam Consumption (per pocket) 101 lbs/hr (45.8 kg/hr)</p> <p>Operating Steam Pressure 125 psi max. (8.6 bar)</p> <p>Compressed Air Connection 1/8" F.N.P.T.</p> <p>Compressed Air Volume 0.5 cfm / 0.014 cmh</p> <p>Boiler Horsepower (per pocket) 2.9 Bhp</p> <p>Supply Connection 1" F.N.P.T.</p> <p>Return Connection 3/4" F.N.P.</p>						

Specifications in parentheses are metric equivalents.  
\*Dryer must be provided with clean, dry and regulated 80 psi +/- 10 psi (5.51 bar +/- 0.69 bar) air supply.

4/20/10

Electrical Service Specifications						
GAS & STEAM						
SERVICE VOLTAGE	PHASE	WIRE SERVICE	OVEN kW	APPROX AMP DRAW		CIRCUIT BREAKER
				60 Hz	50 Hz	
100	1ø	2	--	7.8	8.0	15
115	1ø	2	--	7.8	--	15
208	1ø	2	--	4.8	--	15
220	1ø	2	--	--	3.6	15
240	1ø	2	--	4.4	4.3	15

Electrical Specs are per pocket

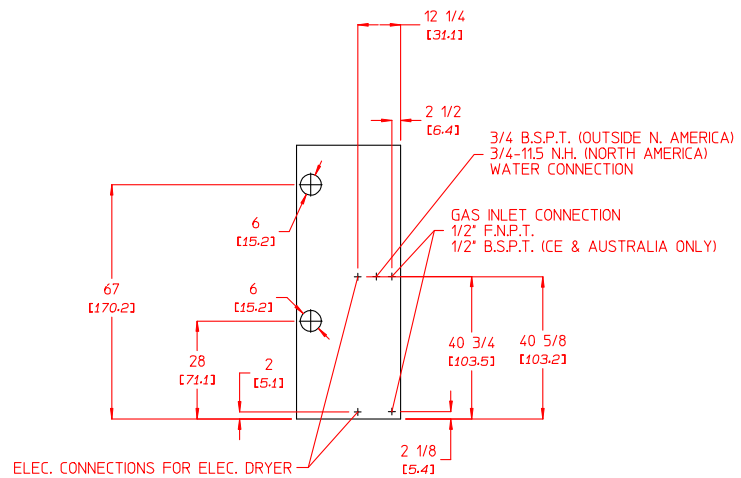

REAR VIEW (GAS & ELECTRIC)

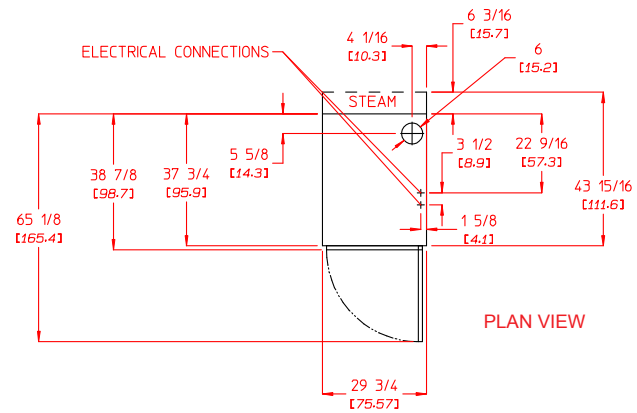

PLAN VIEW

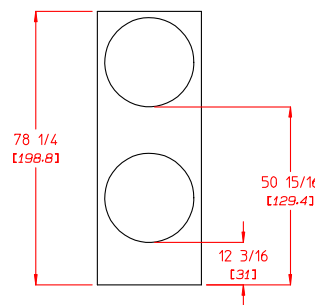

FRONT VIEW

Electrical Specs are per pocket

Electrical Service Specifications						
ELECTRIC						
SERVICE VOLTAGE	PHASE	WIRE SERVICE	OVEN kW	APPROX AMP DRAW		CIRCUIT BREAKER
				60 Hz	50 Hz	
208	1ø	2	15	76.9	--	110
240	1ø	2	15	66.9	66.8	90
208	3ø	3	15	46.4	--	70
220	3ø	3	15	--	43.7	60
240	3ø	3	15	40.5	40.4	60
380-440	3ø	4*	15	--	27.1	45
416	3ø	4*	15	--	25.1	45
480	3ø	3	15	23.1	--	45

web-only document Rev. 8/16/13

88 Currant Road Fall River, MA 02720-4781 • 508.678.9000 • Fax: 508.678.9447 • Email: sales@amdry.com

www.adclaundry.com